

ALARA assessment of a decommissioning activity with VisiPlan

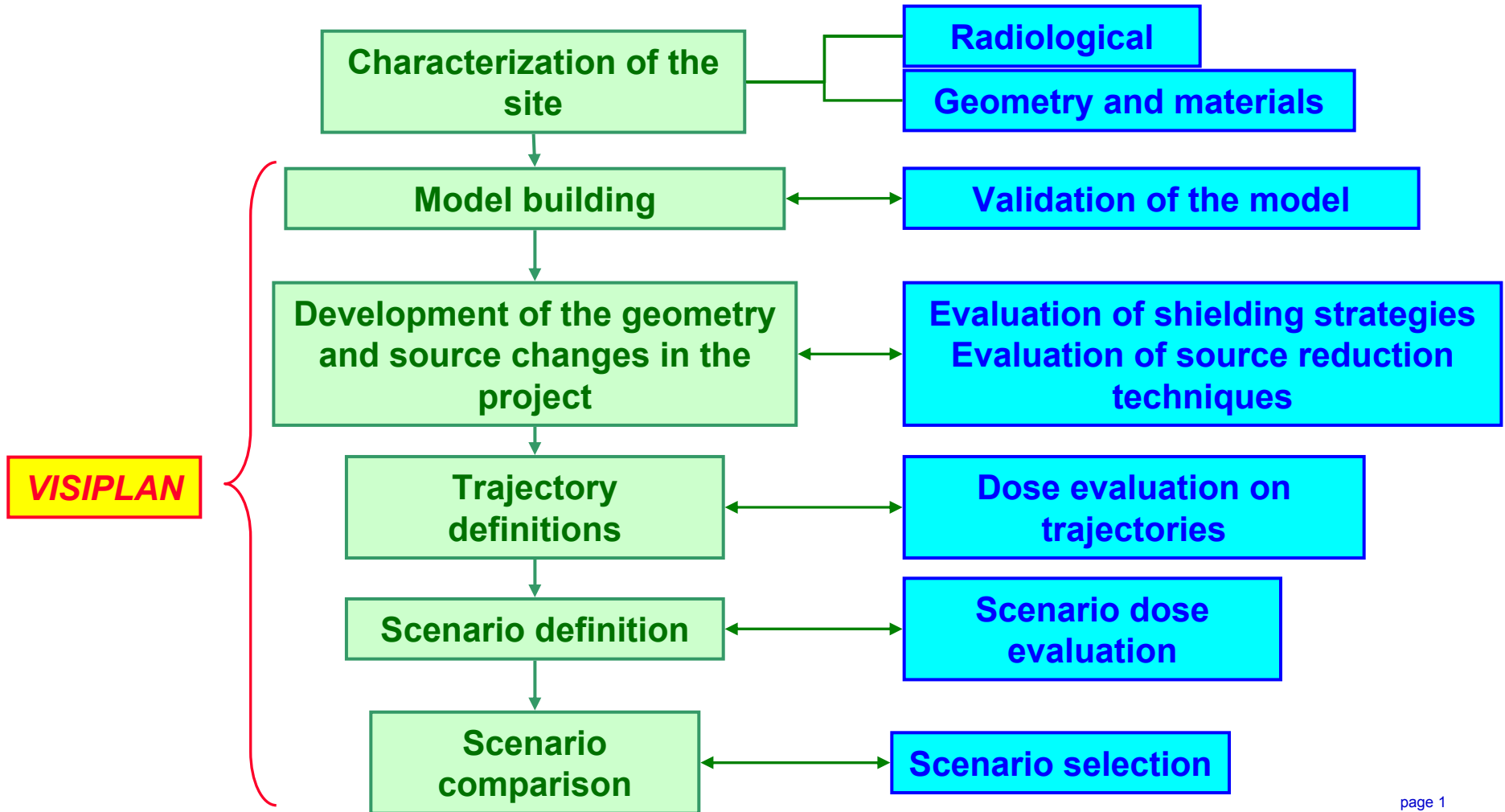

Visiplan

General methodology

- Model building stage
- General analysis stage
- Detailed planning stage
- The follow up stage

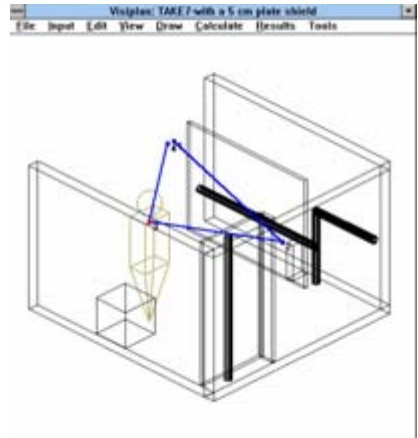
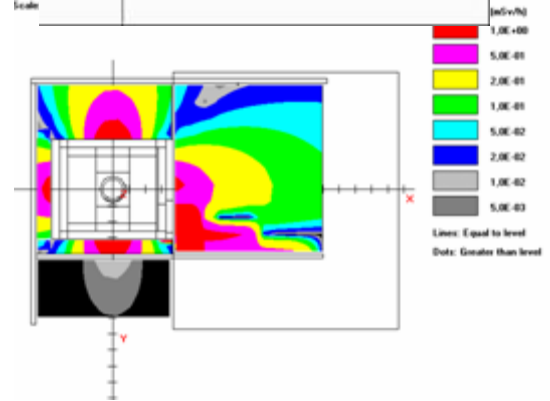
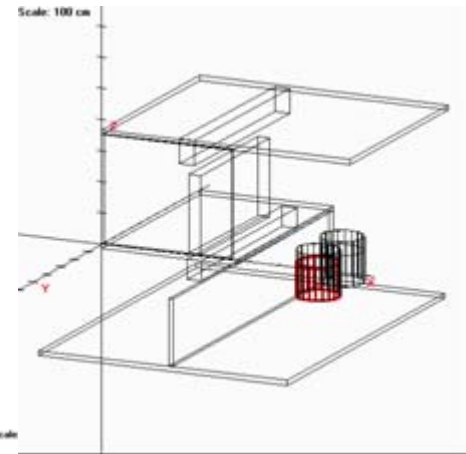
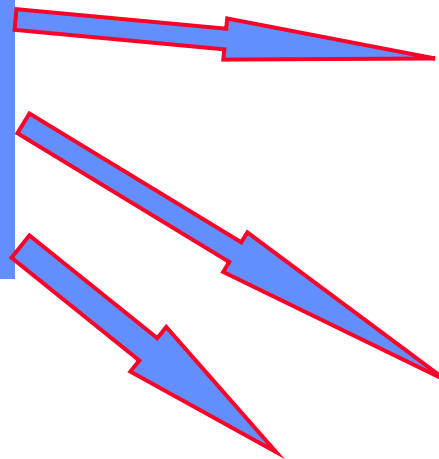
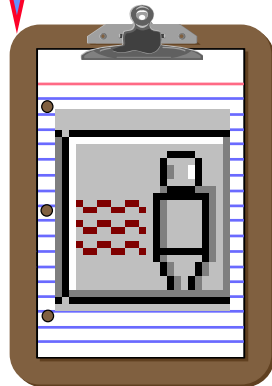
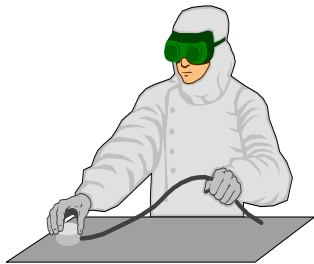

Visiplan

Model building stage

Geometrical input



- From technical drawings
- Survey techniques
- Photogrammetry
- Laser scanning



Primitive volumes

Materials input

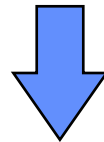

- Technical data
- Experts on site



Materials dataset



Take

Radiological input



- Technical data
- Survey
- Site history



Source dataset

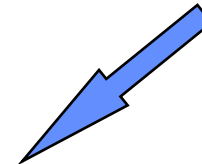

Visiplan

"Take" definition

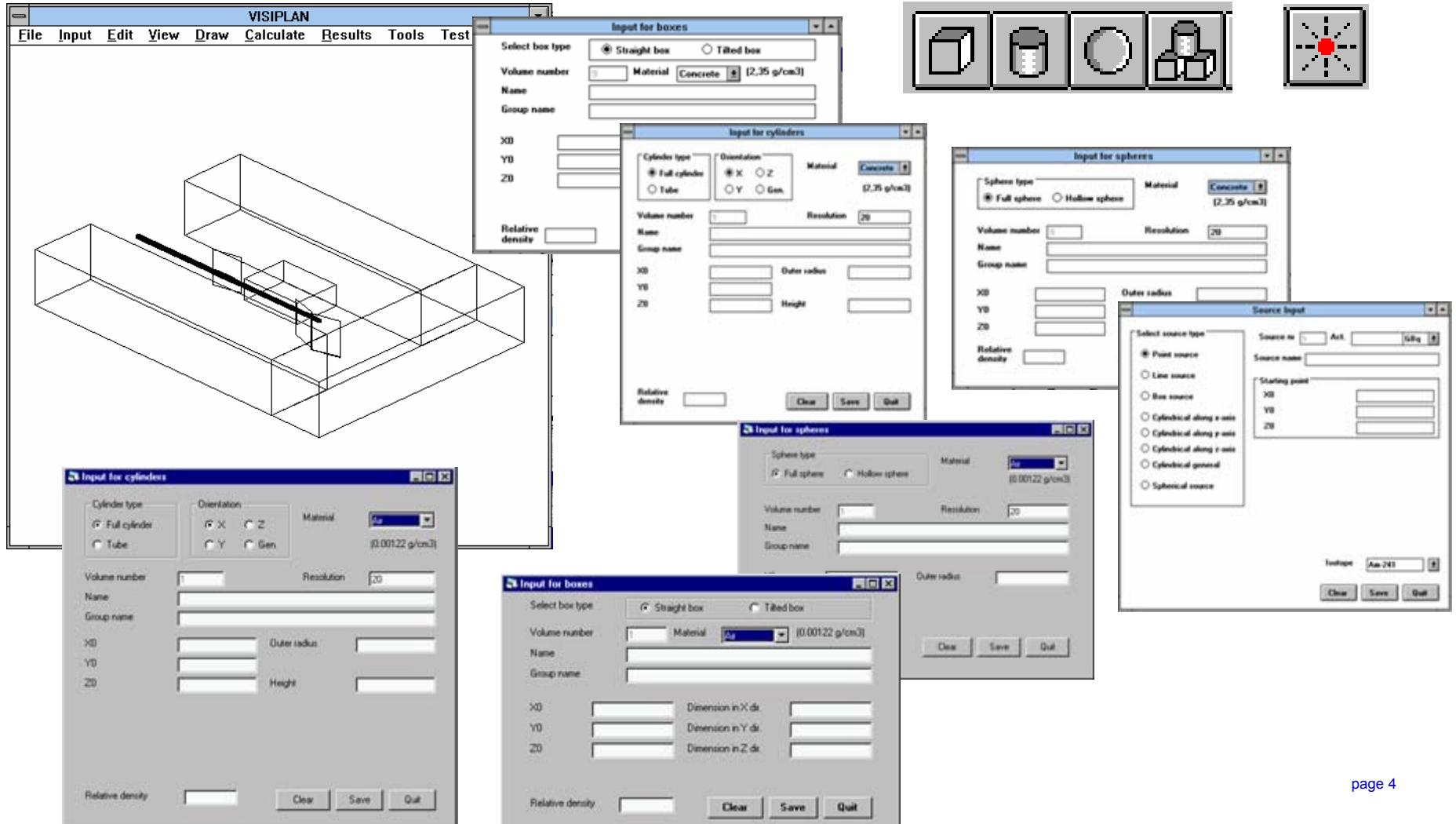

The screenshot displays the Visiplan software interface. The main window shows a 3D wireframe model of a rectangular structure with internal components. Several dialog boxes are open, allowing users to define geometric shapes:

- Input for boxes:** Select box type (Straight box or Tilted box), Volume number, Material (Concrete, 2.35 g/cm³), Name, Group name, X0, Y0, Z0, and Relative density.
- Input for cylinders:** Cylinder type (Full cylinder or Tube), Orientation (X, Y, Z or Gen.), Material (Concrete, 2.35 g/cm³), Volume number, Resolution (20), Name, Group name, X0, Y0, Z0, Outer radius, Height, and Relative density.
- Input for spheres:** Sphere type (Full sphere or Hollow sphere), Material (Concrete, 2.35 g/cm³), Volume number, Resolution (20), Name, Group name, X0, Y0, Z0, Outer radius, and Relative density.
- Source Input:** Select source type (Point source, Line source, Box source, Cylindrical along x axis, Cylindrical along y axis, Cylindrical along z axis, Cylindrical general, or Spherical source), Source no., Act., Gkg, Source name, Starting point (X0, Y0, Z0), and Inshape (Am 241).
- Input for spheres (bottom):** Sphere type (Full sphere or Hollow sphere), Material (Air, 0.00122 g/cm³), Volume number, Resolution (20), Name, Group name, Outer radius, and Relative density.
- Input for boxes (bottom):** Select box type (Straight box or Tilted box), Volume number, Material (Air, 0.00122 g/cm³), Name, Group name, X0, Y0, Z0, Dimension in X dir, Dimension in Y dir, Dimension in Z dir, and Relative density.

At the top right, there is a toolbar with icons for a box, a cylinder, a sphere, a complex shape, and a source input icon.

Basic volumes

- Box
- Tilted box
- Cylinder
- Hollow cylinder
- Tube
- Sphere
- Hollow sphere

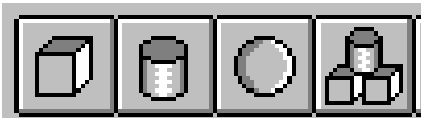

- Now extended with
 - cone
 - bend
 - triangular shapes

Standard Materials

- Concrete
- Iron
- Lead
- Water
- Zirconium
- Aluminum
- Uranium
- Tungsten
- Tin

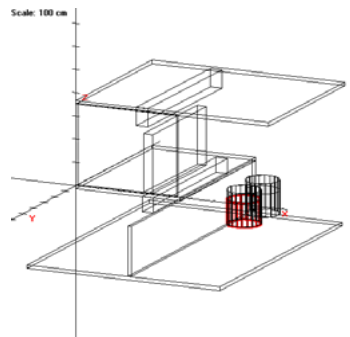

Source Definition

- Single isotopes
- Mixed isotope sets
- Photon spectrum at standard energies
- Point, Line, Box, Cylinder, spherical sources

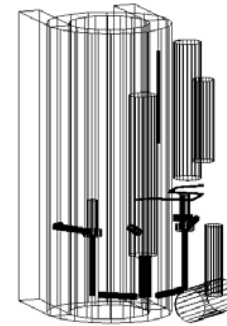
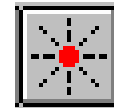

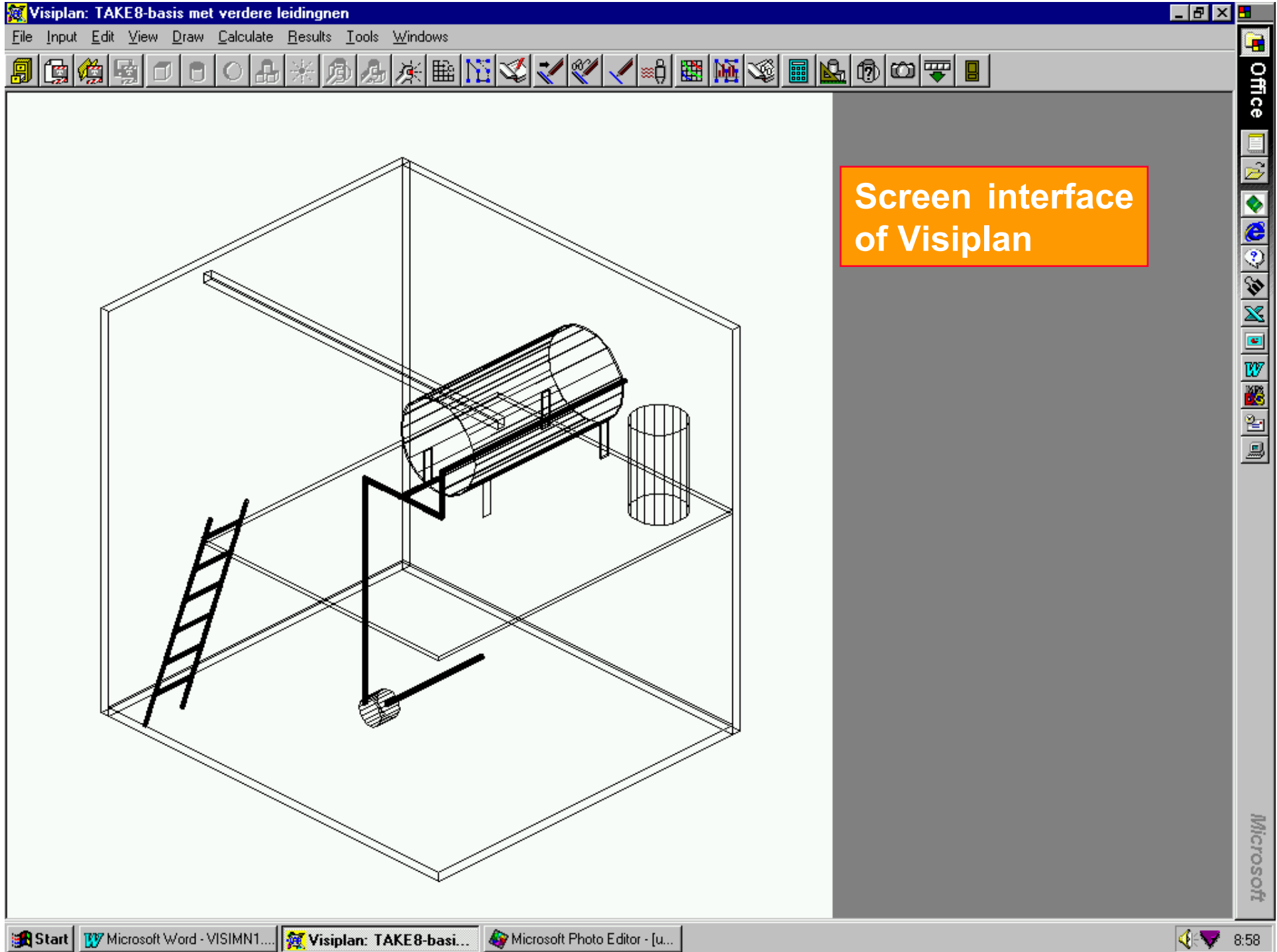

Screen interface
of Visiplan

The geometry can be changed to simulate future events

Descriptions of a site at different moments during the job

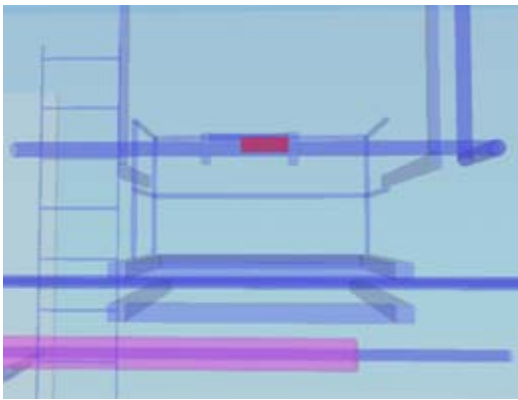

1. Basic situation

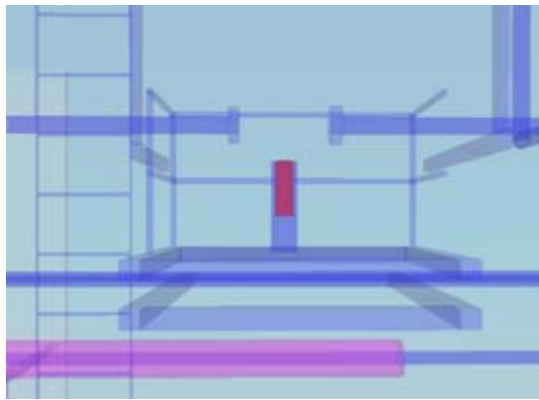

2. Filter housing decoupled

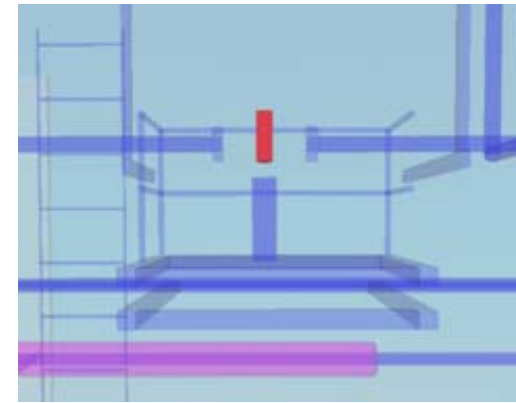

3. Filter out of the housing

Filter replacement
work Almaraz NPP

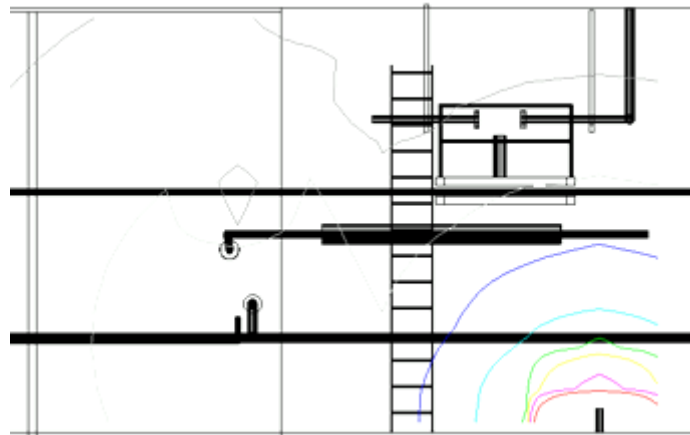

4. Filter on the floor

Radiological Characterization of a site



Traditional

- Site history
- Dose rate measurements (4π) at different locations in the work area
- Spectral Analysis on samples (sweeps, fluids, resins,.....)

New Technologies for source location and source strength evaluation

- Gamma scanning
- Gamma cameras

Source Strength inference from a measured dose rate set

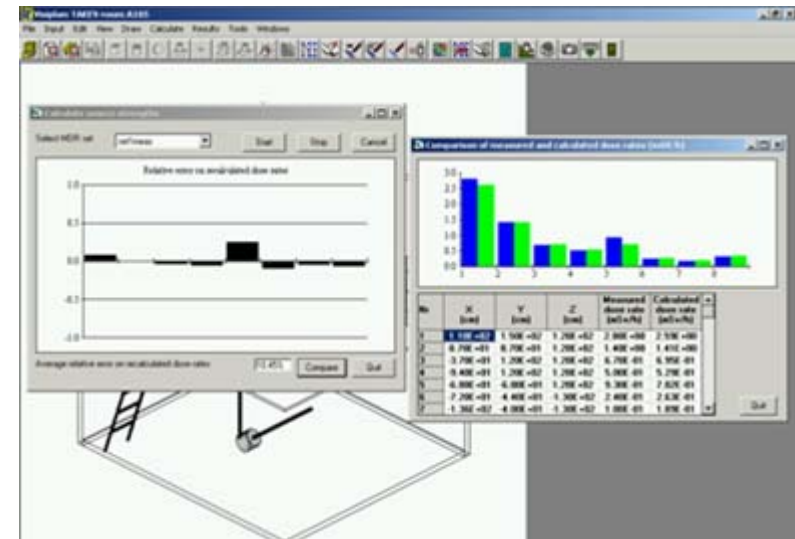
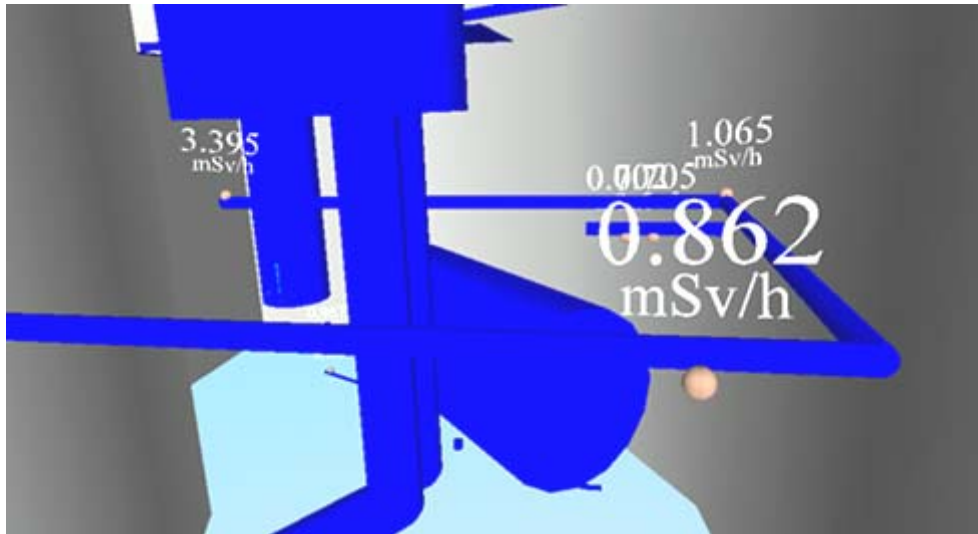

Dose rate measurements at different locations in the work area (3D position + Dose rate)



Visiplan

General planning stage

- First Evaluation based on calculated dose maps
- Evaluation of possible shielding solutions

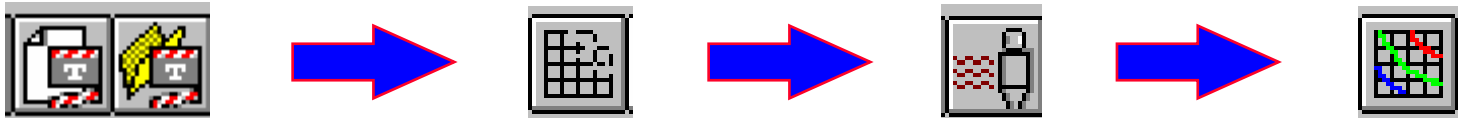

Take 1 *Basic situation*

Take 2 *Shielding solution 1*

...

Take n *Shielding solution n*

- x-, y-, z-grid on screen definition
- Isodose, Pattern or grid dot display
- Dose rate determination at pointer position on the grid
- Display of the source contribution at the pointer position on the grid

Scale: 100 cm

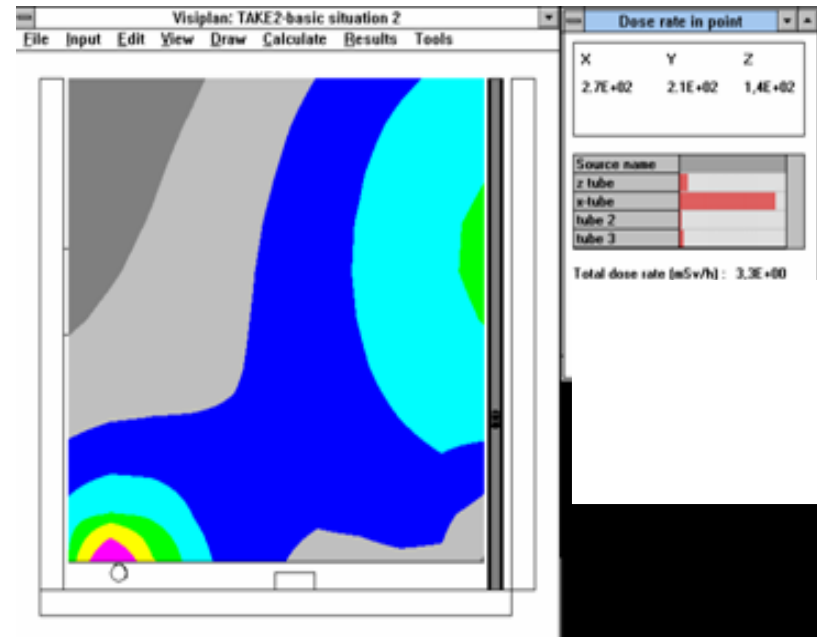
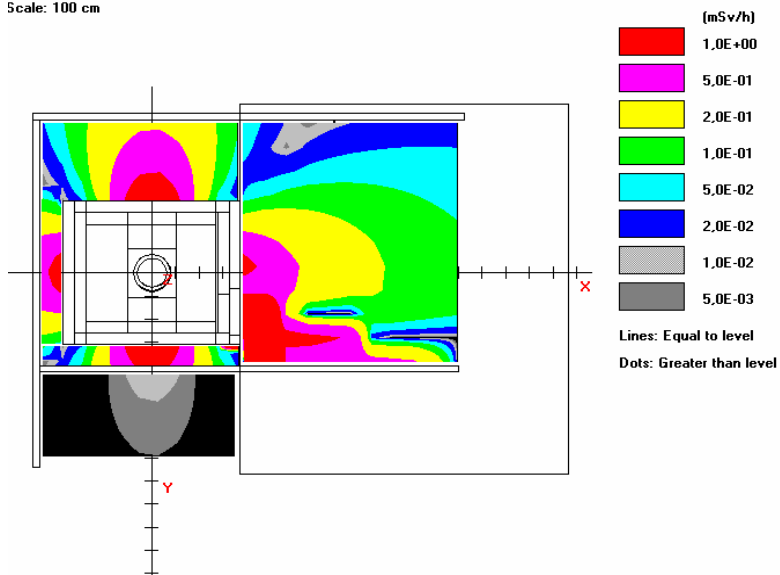

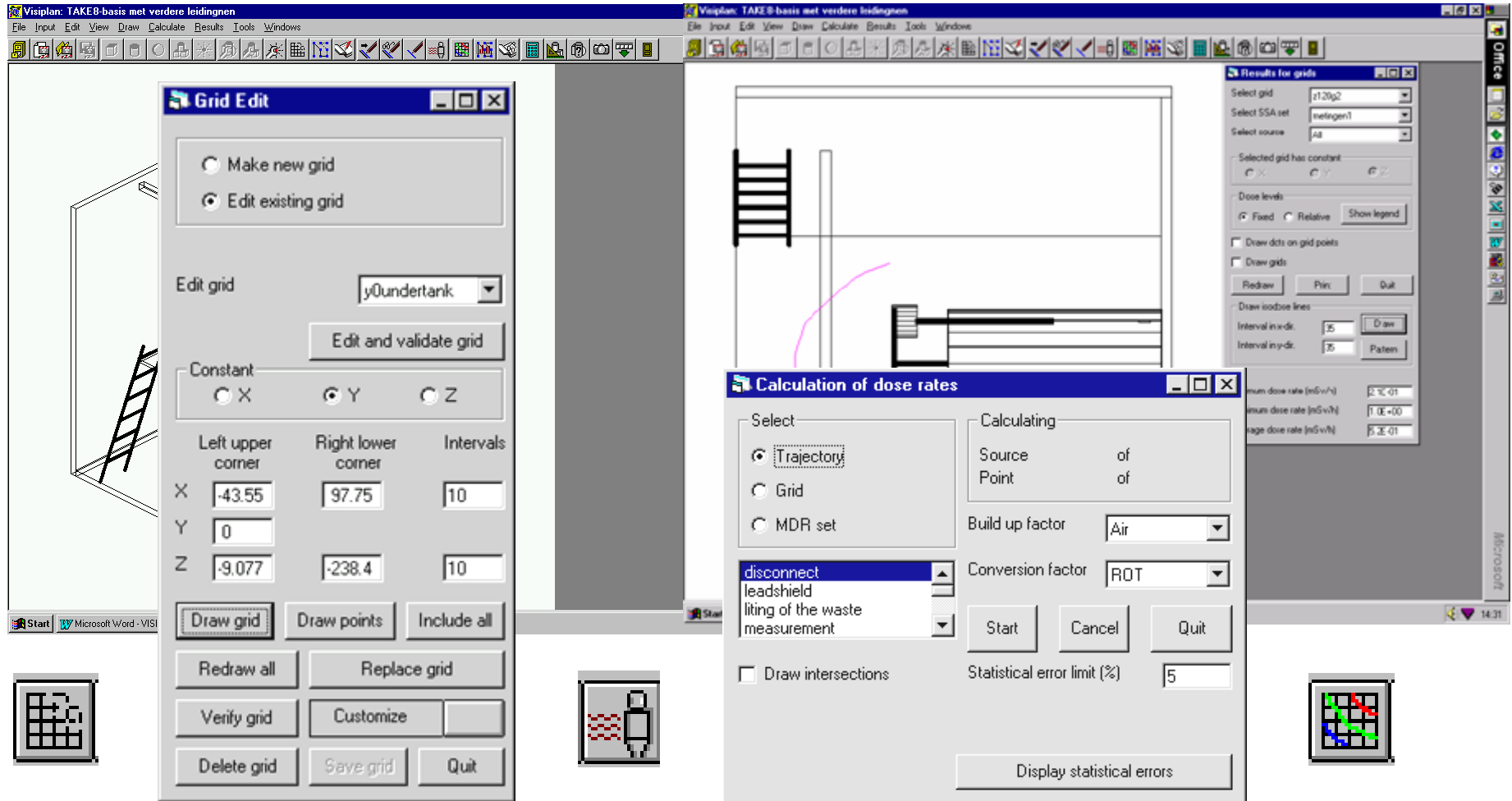

Grid tool

Dose calculation tool

Visiplan

Detailed planning stage

Trajectory definition

- Position
- Task description
- Task duration
- Uncertainty on task duration

Trajectory Results

- Accumulated dose vs time
- Dose rate at task location Dose and dose rate per task
- Contribution of the different sources to the task dose
- Minimum, maximum dose estimate based on the time uncertainty
- Bias with source sensitivity analysis set

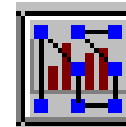
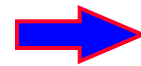
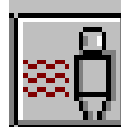
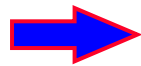
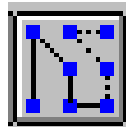

Visiplan *Trajectory tool*

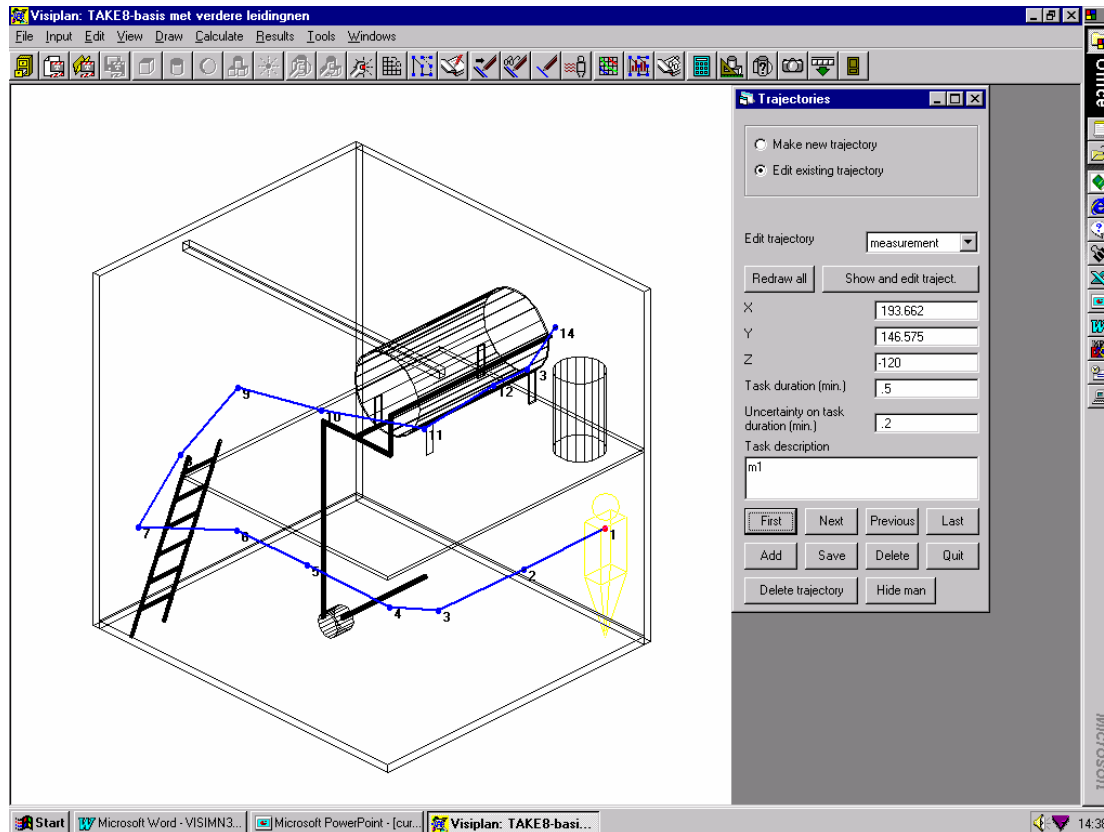

Trajectories define :

- Work position
- Work duration
- Uncertainty in work duration

Visiplan

Calculate Trajectories

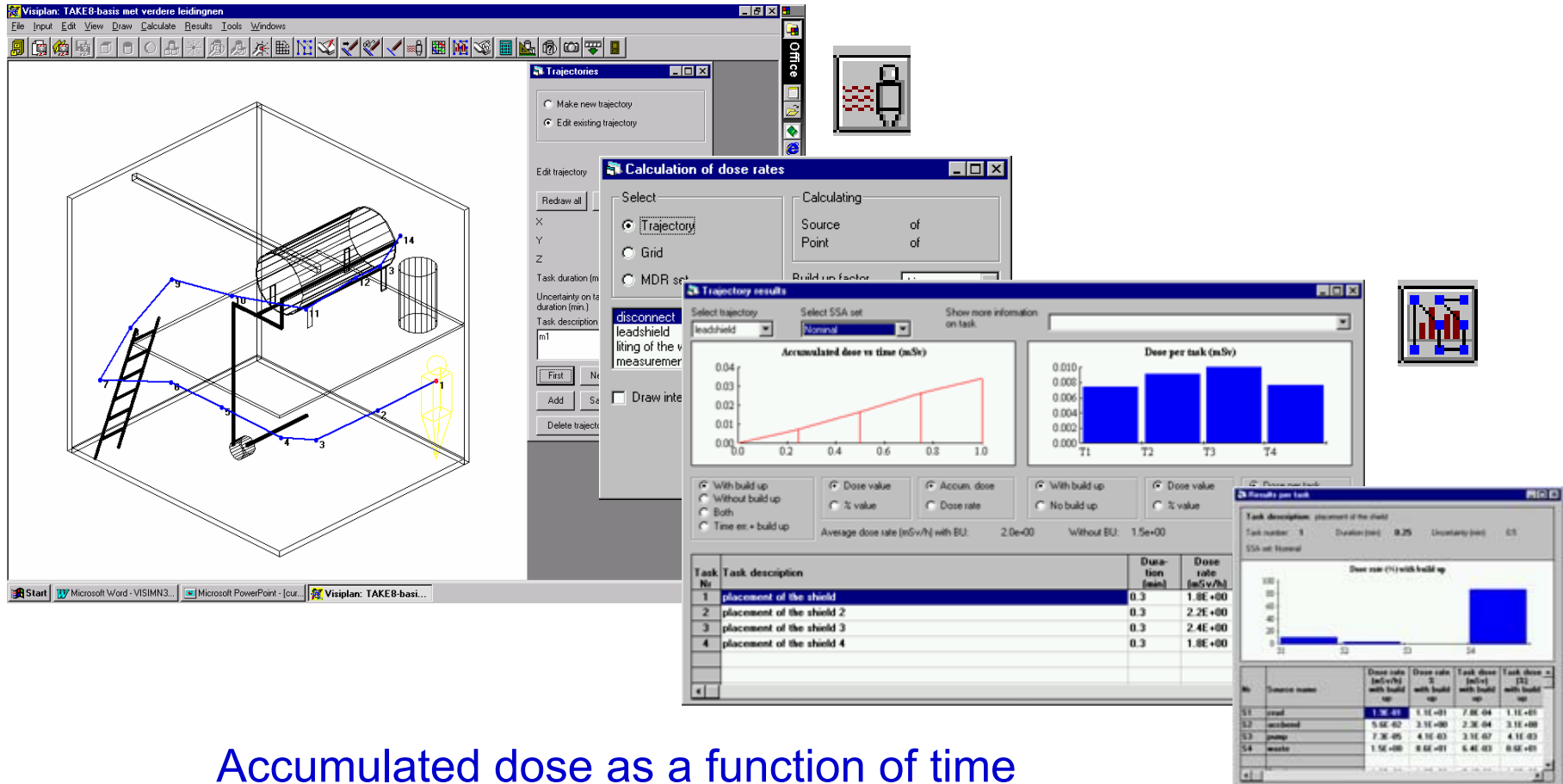

The screenshot displays the Visiplan software interface with several windows open:

- Visiplan: TAKE8-basis met verdere leidingen**: The main workspace showing a 3D model of a facility with a blue trajectory path and numbered points (1-14).
- Trajectories**: A panel with options to 'Make new trajectory' or 'Edit existing trajectory'.
- Calculation of dose rates**: A dialog box with 'Trajectory' selected under 'Select' and 'Calculating' status.
- Trajectory results**: A window containing:
 - Accumulated dose vs time (mSv)**: A line graph showing a linear increase in dose over time.
 - Dose per task (mSv)**: A bar chart showing dose contributions for tasks T1, T2, T3, and T4.
 - Average dose rate (mSv/h) with BU: 2.0E+00 Without BU: 1.5E+00**
 - Task description table**:

Task No	Task description	Duration (min)	Dose rate (mSv/h)
1	placement of the shield	0.3	1.8E+00
2	placement of the shield 2	0.3	2.2E+00
3	placement of the shield 3	0.3	2.4E+00
4	placement of the shield 4	0.3	1.8E+00
 - Results per task**: A window showing a bar chart for 'Dose rate (mSv/h) with build up' and a detailed table of source contributions.

Accumulated dose as a function of time
Dose contribution per source to a task

Visiplan

Scenario Calculations



Scenario definition

- Selection of trajectories in different takes
- Selection of Source sensitivity Analysis file
- Dedicate a worker or a group of worker to a trajectory



Scenario Results

- Collective dose
- Collective dose per trajectory
- Accumulated dose per worker per task

Visiplan Scenarii

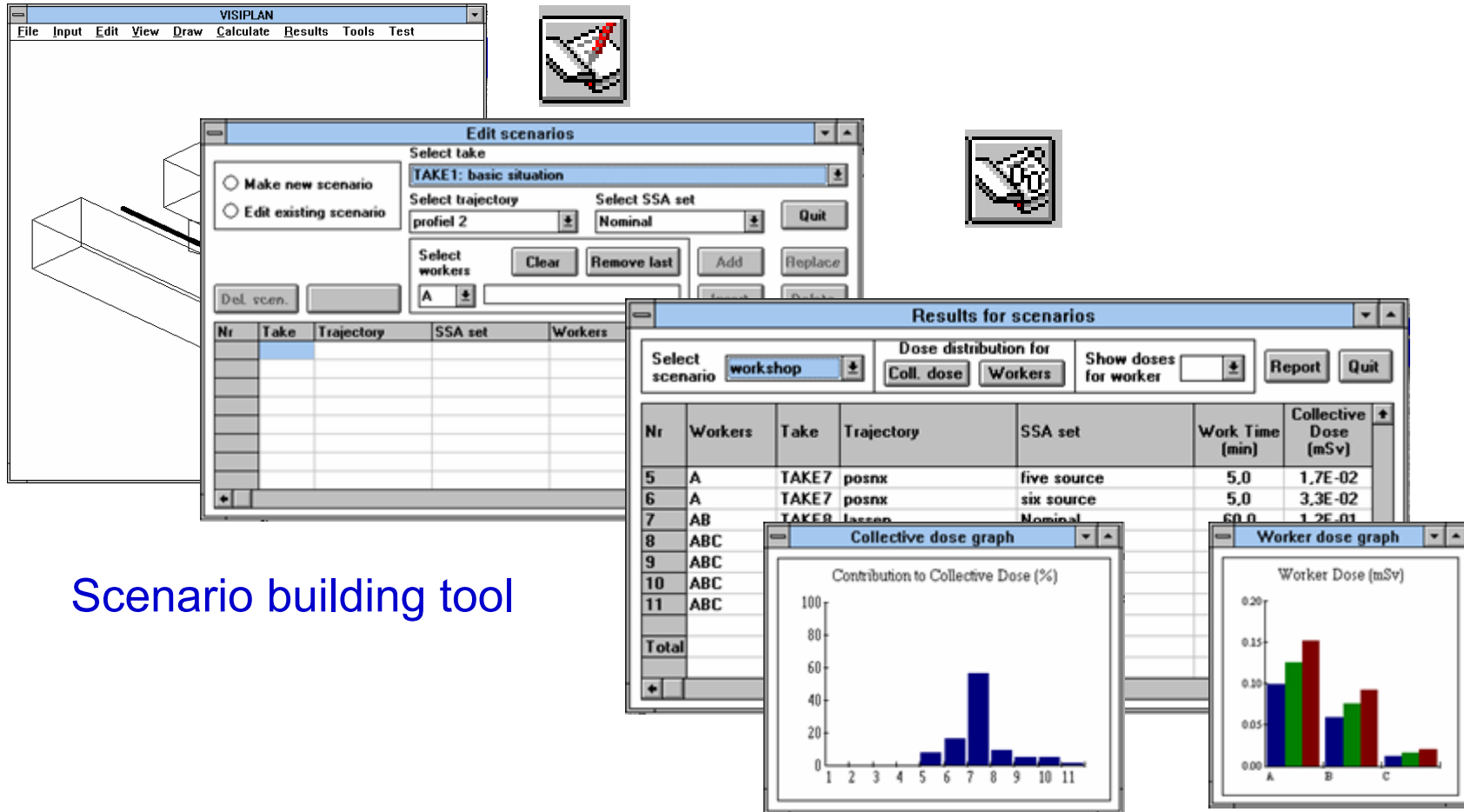

The screenshot displays the Visiplan software interface, which is divided into several functional windows:

- Visiplan Main Window:** Contains a menu bar (File, Input, Edit, View, Draw, Calculate, Results, Tools, Test) and a large empty workspace for drawing.
- Edit scenarios:** A configuration window with options to "Make new scenario" or "Edit existing scenario". It includes fields for "Select take" (TAKE1: basic situation), "Select trajectory" (profiel 2), and "Select SSA set" (Nominal). It also features a "Select workers" section with buttons for "Clear", "Remove last", "Add", and "Replace".
- Results for scenarios:** A window showing a table of results for a selected scenario (workshop). It includes a "Dose distribution for" section with "Coll. dose" and "Workers" options, and a "Show doses for worker" dropdown. The table below shows the following data:

Nr	Workers	Take	Trajectory	SSA set	Work Time (min)	Collective Dose (mSv)
5	A	TAKE7	posnx	five source	5,0	1,7E-02
6	A	TAKE7	posnx	six source	5,0	3,3E-02
7	AB	TAKER	lassen	Nominal	60,0	1,2E-01
8	ABC					
9	ABC					
10	ABC					
11	ABC					
Total						

- Collective dose graph:** A bar chart titled "Contribution to Collective Dose (%)" showing the percentage contribution of each scenario number (1-11) to the total collective dose. Scenario 7 has the highest contribution, around 60%.
- Worker dose graph:** A bar chart titled "Worker Dose (mSv)" showing the dose for workers A, B, and C across different scenarios. Worker A has the highest dose, around 0.15 mSv.

Scenario building tool

Scenario result tool

Visiplan

Scenario Comparison

Scenario Comparison Results

- Collective dose (man*Sv)
- Max individual dose (mSv)
- Intervention time (h)
- Collective time (man*h)

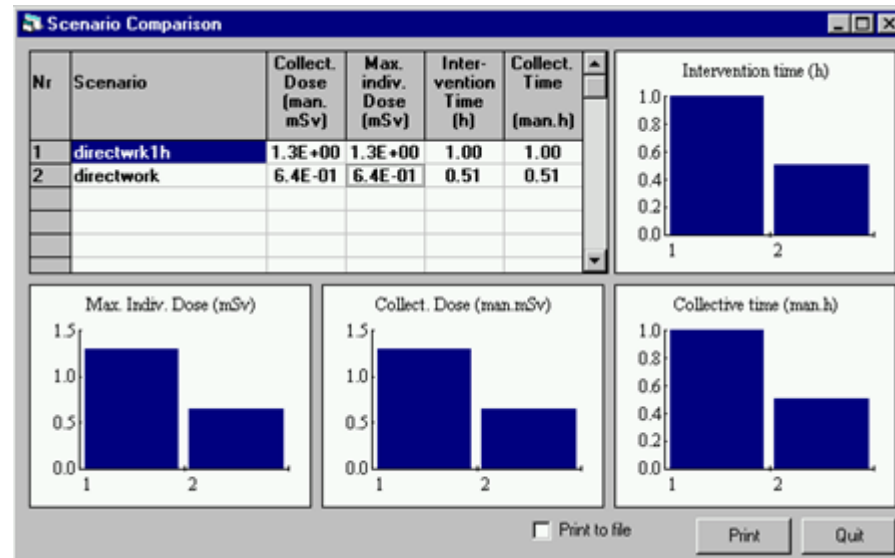

Easy and clear communication of the results through VRML files

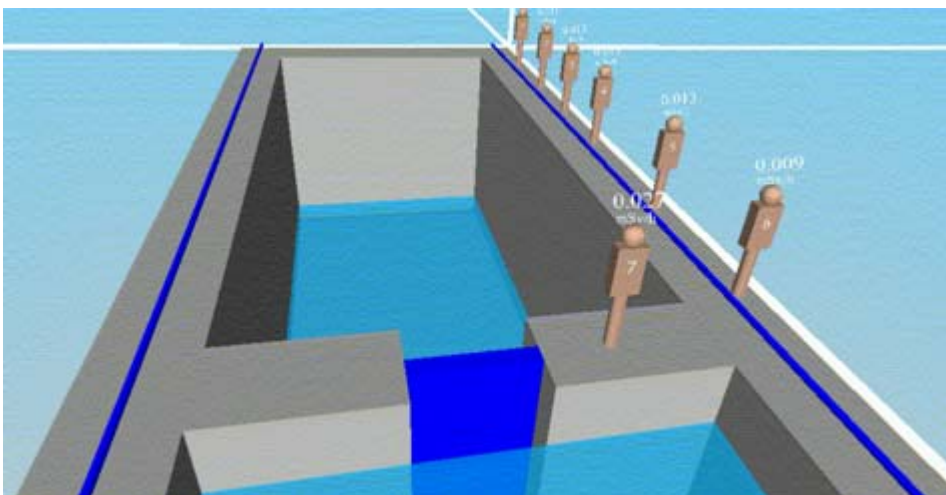
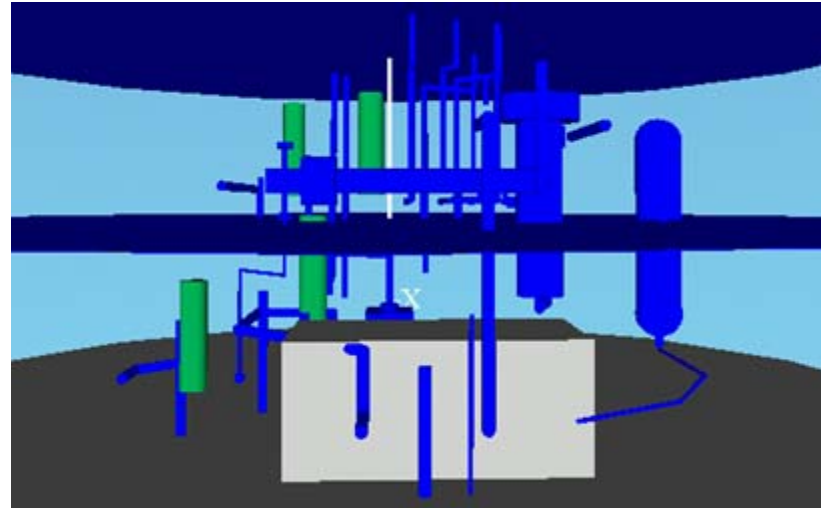
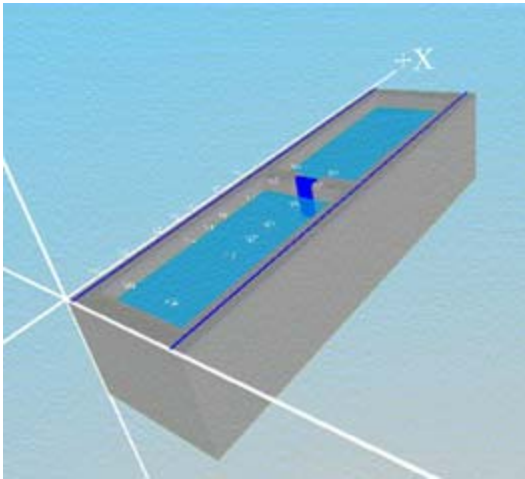

Simple or complex geometries in full interactive 3D, readable with standard VRML tools from the internet.

Shielding calculation

Point kernel with buildup correction

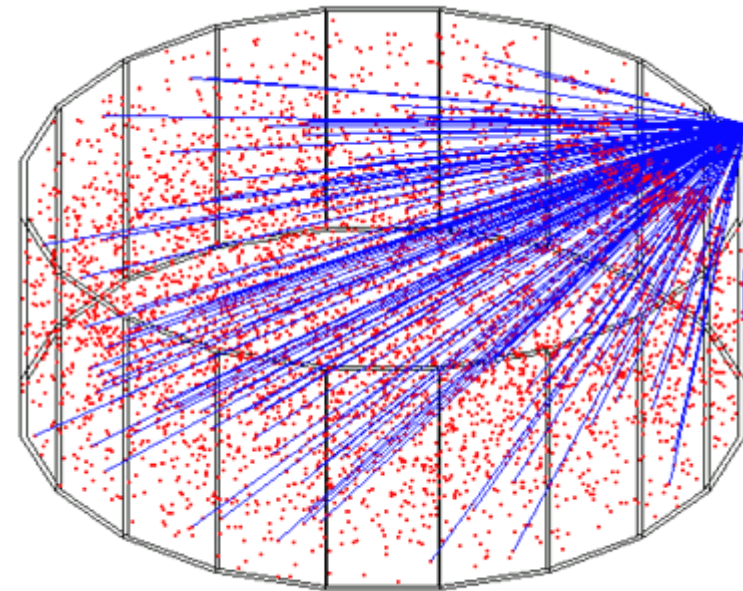
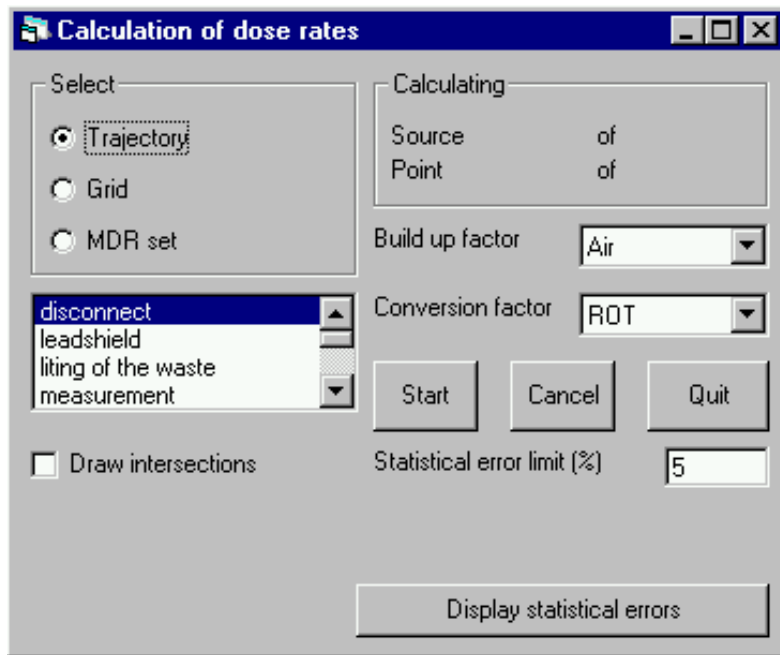

Standard ANSI materials for attenuation and Buildup calculations.
Calculations on grids, trajectories and measured dose sets

Gamma Scanning

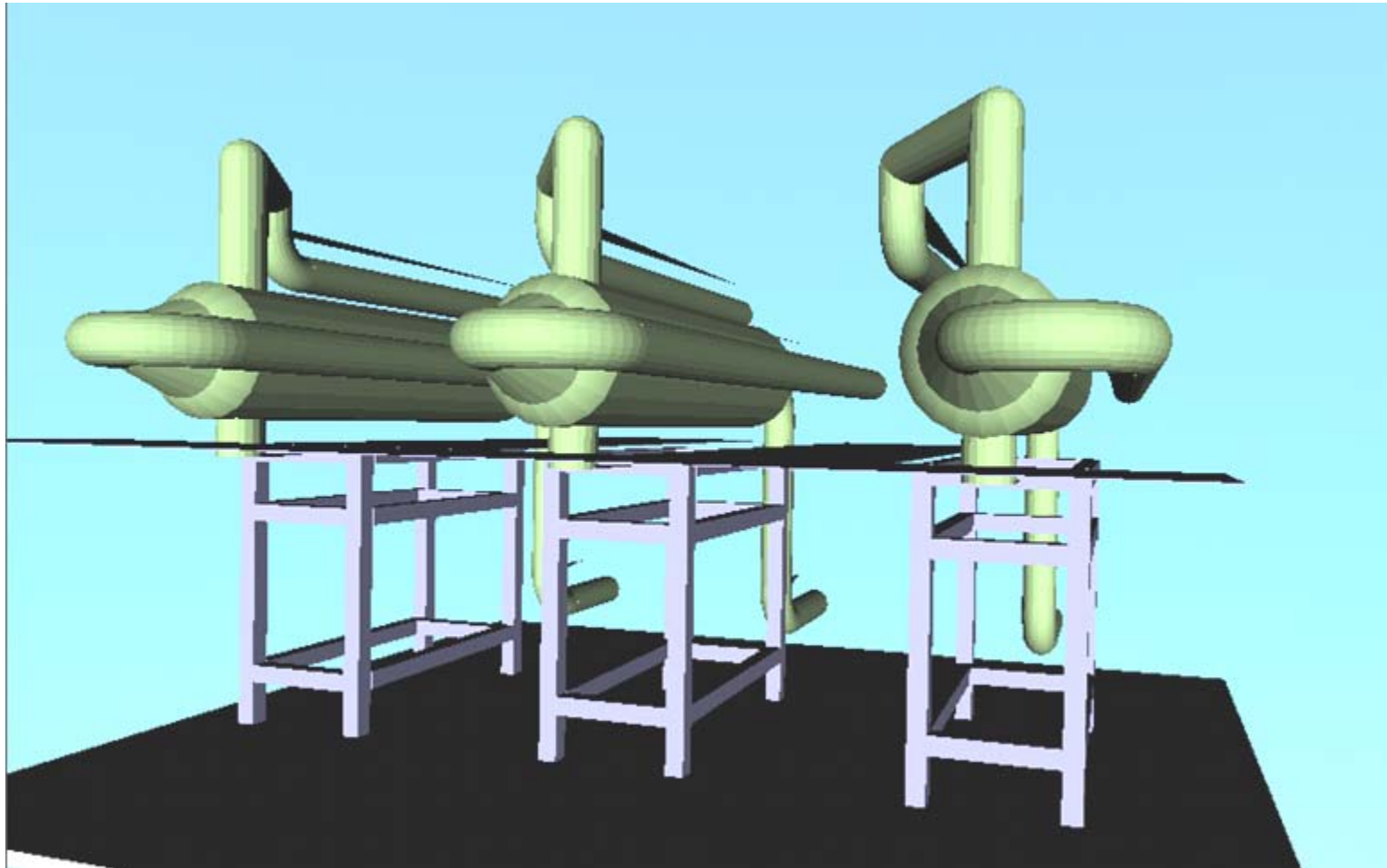

Intensity map scan 2

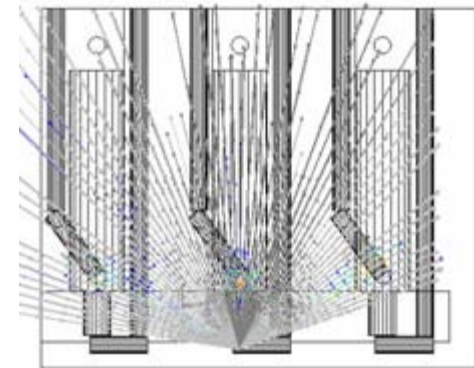
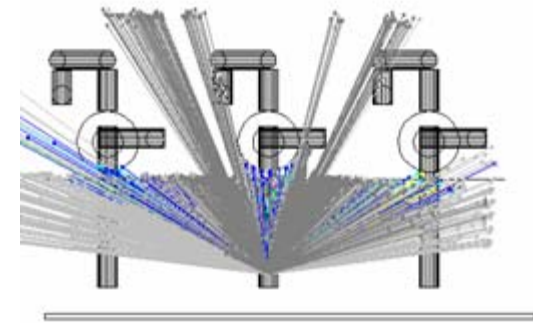
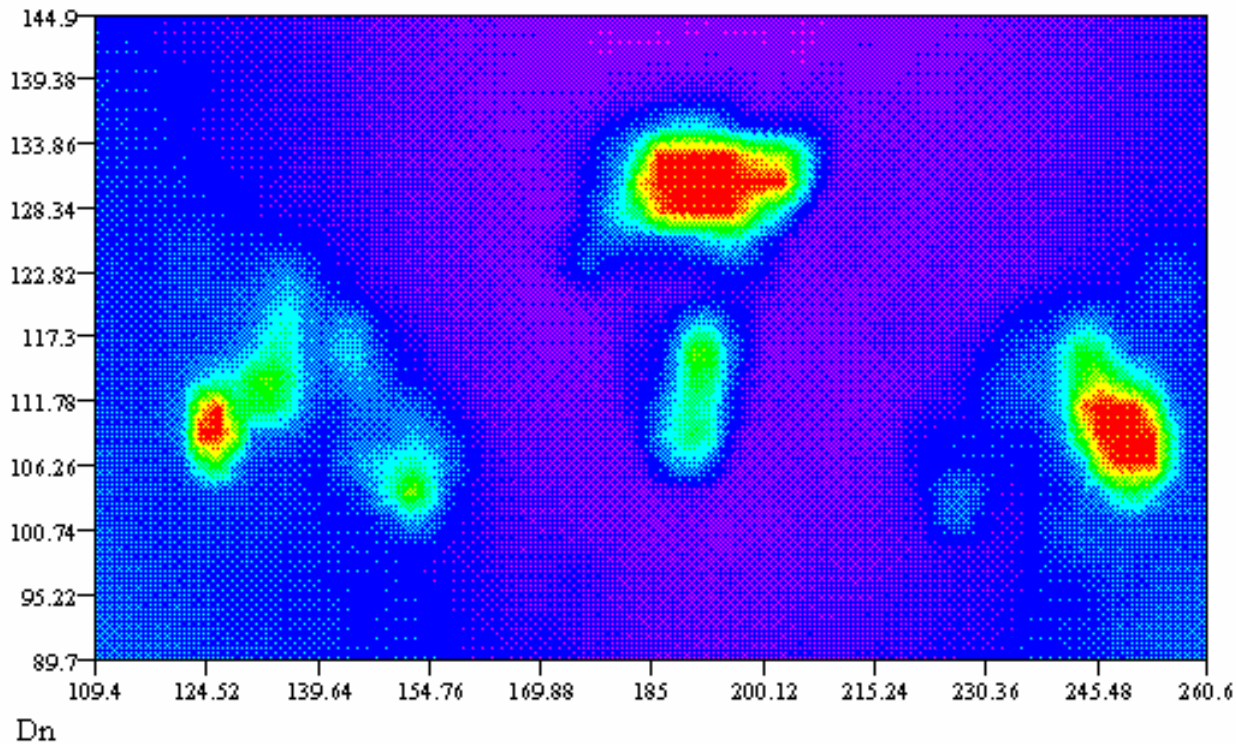

Range 69 to 600 cps, from purple over blue to red, cut-off at 600 cps

Visiplan *Developments*

- VRML Convertor
- HTML-VRML web-site generator

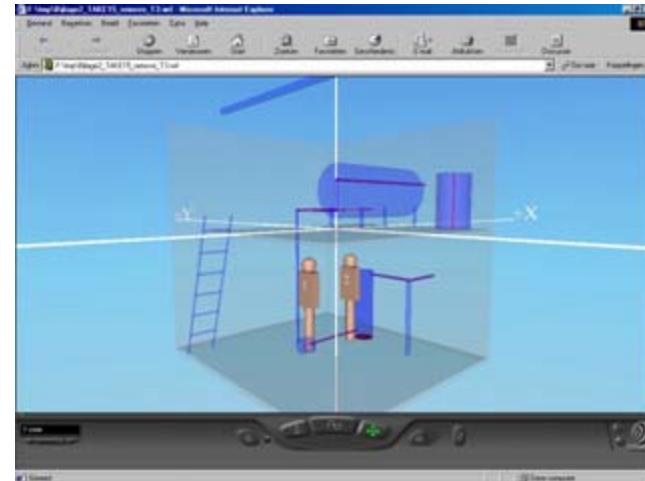

Select study type: Select scenario: without shield

Select trajectory: TAGE11_Lernum T1_Simone

Scenario :without shield

Geometry Check	Trajectory	SSA	WORKER(D)
TAGE11	trajec.T1	Shield	A
TAGE11	trajec.T2	after T1	A
TAGE11	trajec.T3	after T2	A
TAGE11	pat.mont	after T3	AB

Visiplan tools

The convertor

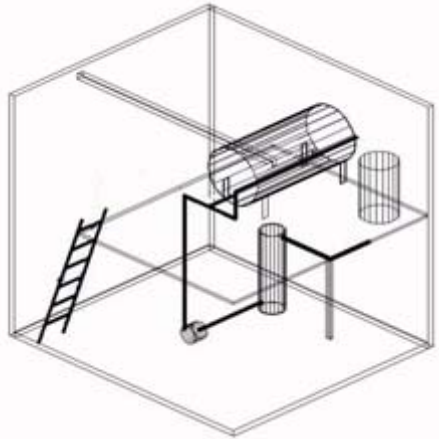

Take : geometrical and radiological environment

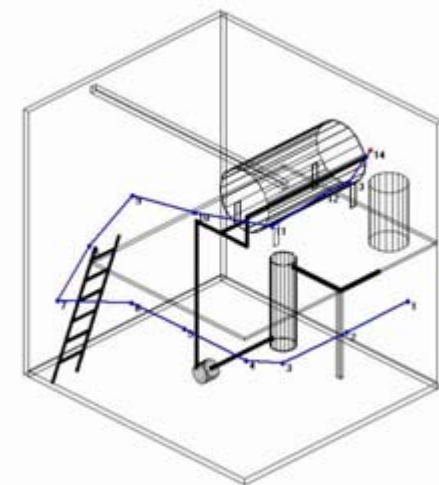
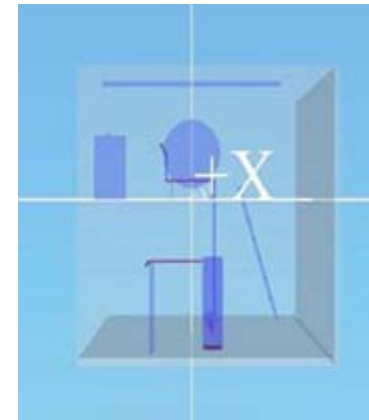

Trajectory

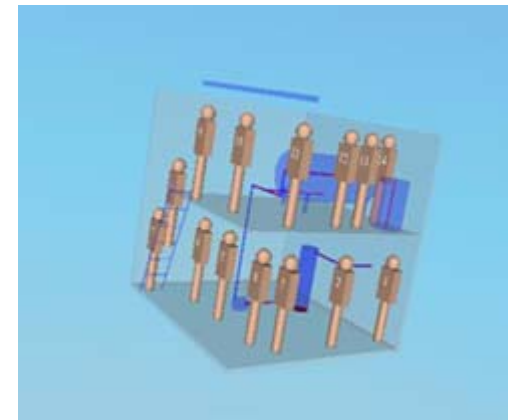

Visiplan tools

Ambiant changes

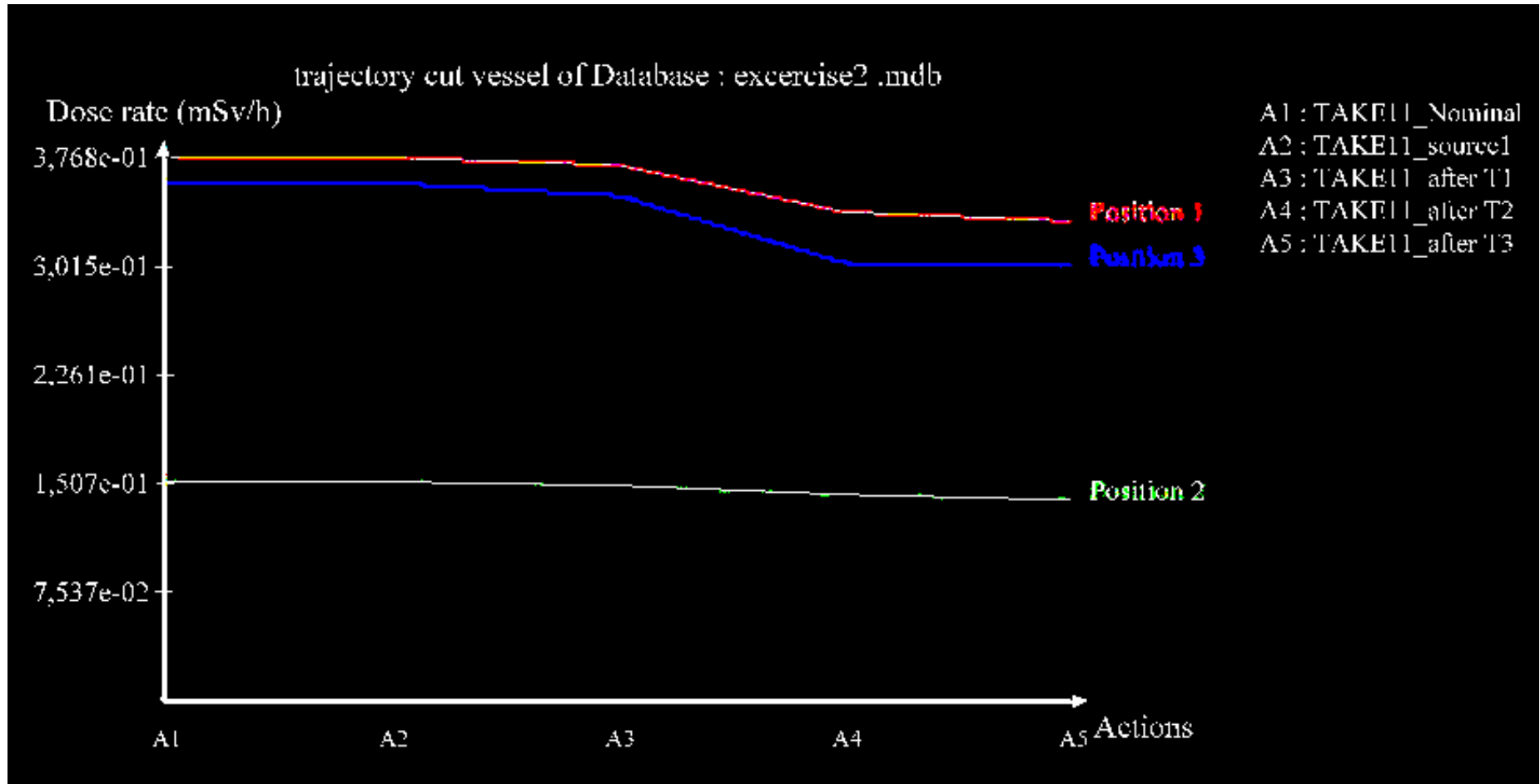

Evolution of the dose debit to different actions



Visiplan tools *Grids*

Pattern

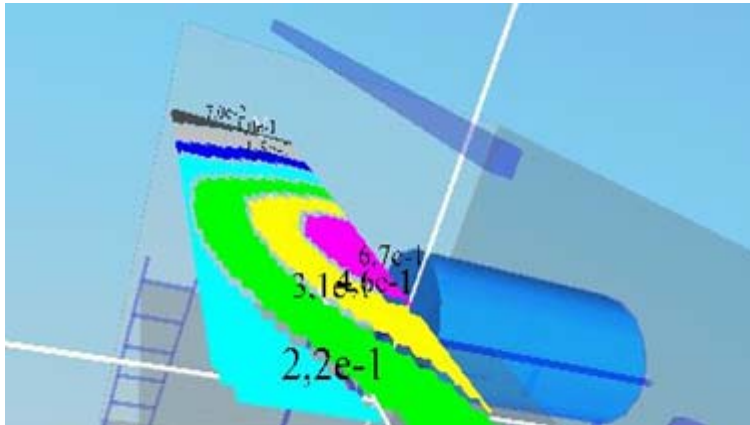

Isodose line

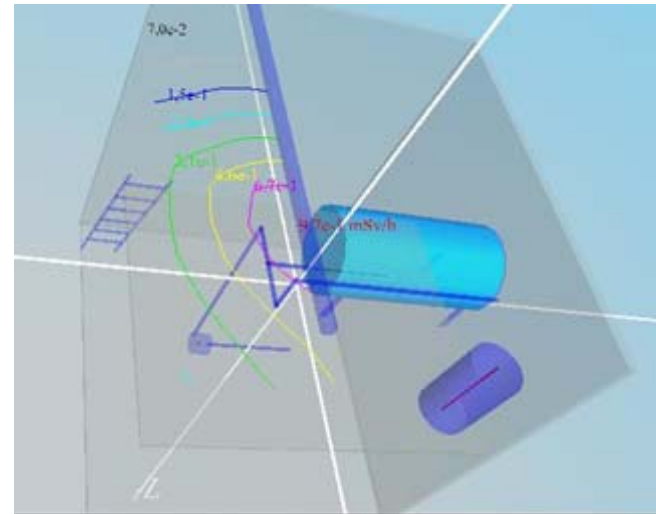

- Hot spots
- Risk areas
- Dose evolution

Source contribution

